

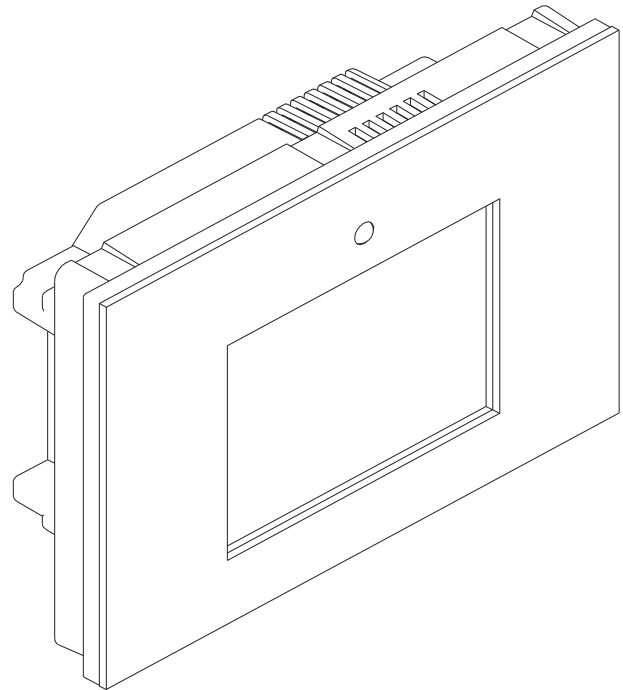

DESCRIPTION

aSmart is a home management device designed to satisfy the most common home automation and control needs. According to its integration philosophy, this model practically does not require any installation.



APPLICATIONS

aSmart is suitable for installation in both new buildings and renovations of:

- Flats.
- High-rise buildings.
- Secondary residence.
- Lofts.
- Offices.
- Semi-detached houses.

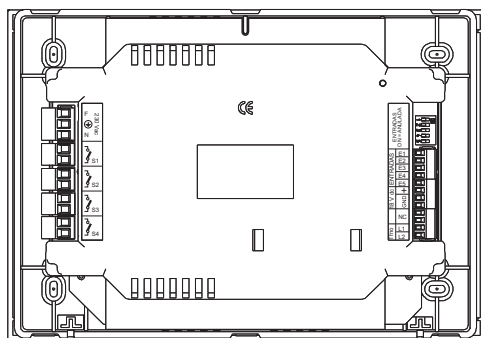

FUNCTIONS

Heating & Heating/cooling Control and Management.

Intrusion Alarm:

Dissuasive siren incorporated.

Calls the three programmed telephone numbers as a warning.

Presence Simulator.

Lighting Control.

Visualization of power consumptions:

Instantaneous consumption.

Cumulated consumptions (days, months)

Connection time of the heating/heating/cooling.

Warning message when power usage exceeds the configured power threshold.

Fire Alarm.

Power Failure Alarm

Voice Mailbox.

Answering machine.

Hands-free telephone.

Remote phone control.

DESCRIPTION OF THE FUNCTIONS

HEATING/COOLING

aSmart has two possible configurations:

CONFIGURATION BC (Thermostat) - this is the original factory default configuration

CONFIGURATION BB (ON-OFF) - This configuration is set through the aS.1001 screen from the phone menu (See Installation's Manual)

1. CONFIGURATION BC (Thermostat)

aSmart is the home thermostat. By setting this configuration the user will control a heating system with temperature management. It has three operation modes:

MANUAL, AUTOMATIC and OFF.

In Manual Mode the user selects the set point temperature. The system will operate continuously when the room temperature is lower than the set point temperature. Once the temperature rises above this set point, the device will stop operating.

In Automatic Mode the user selects up to 3 on-off daily cycles with their set point temperature and in each of these cycles device works exactly the same way as on the manual mode. On this mode an anti-freeze set point can be set. This anti-freeze set point forces the heating system to turn on when it detects an extremely cold temperature below this set point temperature being out of cycle.

2. CONFIGURATION BB (ON-OFF)

By setting this configuration the user will control a Heating/cooling system without temperature management, it works as a switch. It has the same operation modes: MANUAL, AUTOMATIC and OFF. On the manual Mode, system will be continuously operating, and on the automatic mode it will operate according to the cycles selected by the user.

INTRUDER ALARM MANAGEMENT

This efficient alarm system can be easily managed by the user himself. In the event of an alarm situation, the system will call to the 3 telephone numbers previously set up by the user, and will send an "Intruder Alarm" message" to the user informing him of the situation. As the system also has a talk/listen-in feature, the user will be able to know what is going on in his home and deter the intruder. When system does not get an answer it will call the next number set up by the user. Once he has verified the incident the user will be able to cancel calls to the rest of the numbers set up. It is also possible to adjust the sensitivity of the sensor. The unit has an internal siren.

PRESENCE SIMULATION

An active way to increase security is making your home look occupied when it is empty (holidays, long term absences from home,...). aSmart enables the user to program the light on and off timings for each week day in order to avoid differences between the daily life and the absence from home. Keeping some light on and activating this feature home lights will turn on and off according to the timing set up on simulating the presence in the house. Once the intruder is inside the house, and being detected by the sensor, the system will disable this feature and will turn on the lights.

LIGHTING CONTROL

aSmart is intended to contribute to achieving savings and energy efficiency. aSmart gives the user the possibility to switch on and off the lighting system of his home. Therefore important energy savings will be achieved thanks to its function to turn off all the lights at once. From aSmart with just one tap, the user will be able to switch off all the lights at once when he leaves the house. Once the user comes back home and aSmart detects him/her, it will turn on the lights.

VISUALIZATION OF POWER CONSUMPTION.

Important energy savings will be also achieved thanks to the visualization and the analysis of the consumption. aSmart informs the user of instantaneous home energy consumption (Kwh.), the accumulated power consumption for the current day, and the connection time of the heating/heating/cooling. In the same way it shows the power consumption for the last 7 days and the last 12 months, as well as the connection time of the heating/heating/cooling within these periods. aSmart has also an alarm warning in case of high energy consumption. The user set up a power threshold, and the system will alert the user when power usage exceeds the configured power threshold.

FIRE ALARM MANAGEMENT

aSmart includes a temperature sensor to detect sudden temperature increases above 7°C/minute. Temperature estimated to put into operation a thermovelocimetric sensor for fire-detection purposes.

POWER FAILURE ALARM MANAGEMENT.

In the event of power failure system will alert the user to be aware of any loss of or damage to his frozen food. The power outage must be at least 1 minute in length to give rise to this phone alert. The user will be also informed of the reestablishment of power supply.

VOICE MAILBOX

aSmart includes a Voice Mail recorder which can store up to a maximum of 9 Voice Mail messages (30 seconds/message time). These messages can be reproduced later as many times as necessary.

ANSWERING MACHINE.

This Voice Mailbox is able to record messages coming from external telephone calls. This answering machine function is provided with a factory default pre-recorded voicemail outgoing message and the user can also record his own greeting message. The user can select the outgoing message for incoming calls.

TELEPHONE.

aSmart is a hands-free telephone. The user can make outgoing calls and receive incoming calls.

TELEPHONE REMOTE CONTROL

The heating/heating/cooling, intruder alarm and messages functions included in aSmart system can be controlled remotely from any telephone line. Key-protected access, a menu of pre-recorded voices enables aSmart to communicate with the user and guide him up to the functions he wants to control. The user interacts with system using the telephone keypad, which is able to generate multi-frequency DTMF tones which enable the engine to fulfill its interlocutor orders.

PHYSICAL DESCRIPTION

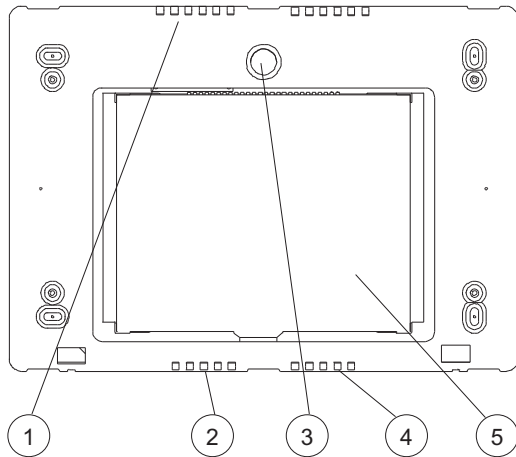

- 1 Loudspeaker.
- 2 Unidirectional microphone.
- 3 Motion sensor.
- 4 Temperature sensor NTC.
- 5 5,7" LCD Touch Screen.

Image of frontal view without the beautifying frame. Identification of the aS.1001 typical elements and their location.

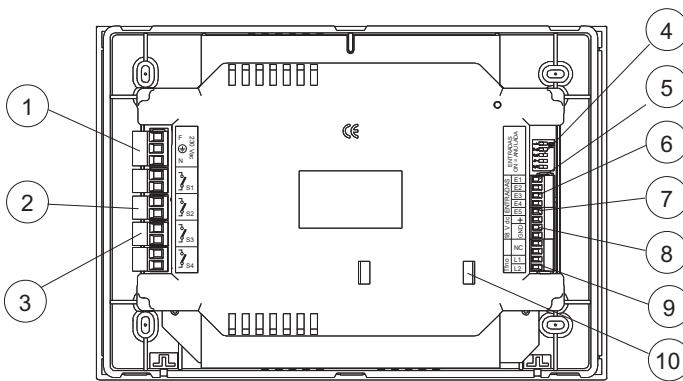

- 1 Power Supply 230 Vac 50 HZ
- 2 Outlet for Heating/cooling control.
- 3 Outlet for lighting control.
- 4 Input Termination Switch.
- 5 Input for intrusion external sensor E1.
- 6 Input for fire external sensor E3.
- 7 Input for current sensor E5.
- 8 Outlet for external sensors supply.
- 9 Connection to the telephone line.
- 10 Internal battery location.

Image of back view. Identification of inputs and outlets used by aS.1001 and their location.

DESCRIPTION OF TERMINALS DETAIL

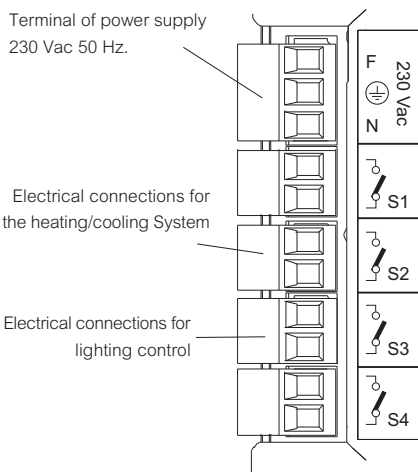

Detail of terminals of the relay outlets. Free from any electrical connection to a source of potential difference.

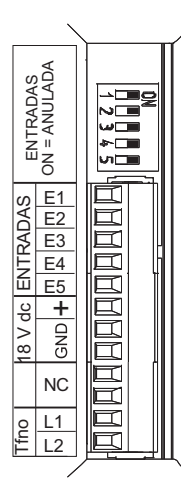

Bridging or disabled inputs

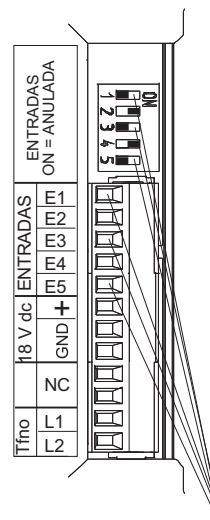

Enable-inputs, E1, E3 and E5

Optionally additional intrusion and/or fire sensors can be connected. In such a case it is important to put switches 1 and/or 3 in OFF mode to enable inputs E1 and E3. It is possible to feed the external sensors in a number below 10 through the internal source of supply. This ensures the continuous supply of external sensors in case of power outage. Connect E5 to current sensor and therefore switch # 5 should be in OFF mode as shown in figure.

DESCRIPT OF DISPLAY LCD Touch

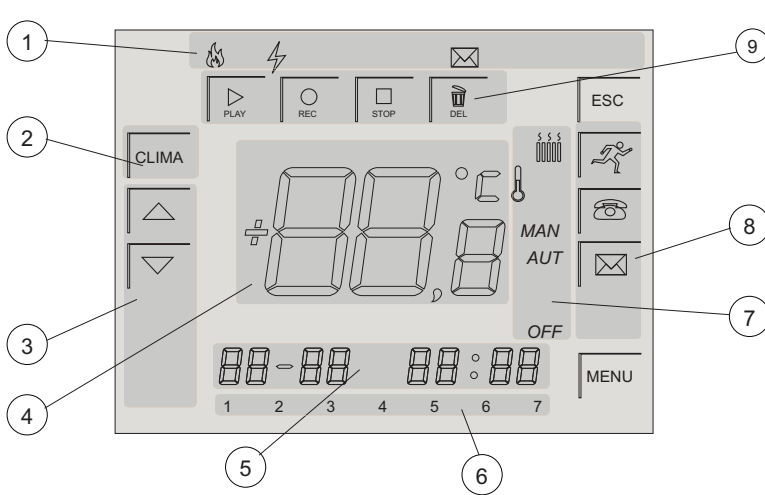

- 1 Icons of activated functions.
- 2 Command buttons.
- 3 Navigation buttons.
- 4 Main indicator for measures and levels.
- 5 Secondary indicator for dates and meters
- 6 Day of week indicator
- 7 Operation status indicator led
- 8 Functions selection buttons.
- 9 Voicemail control buttons.

Control elements location and LCD Touch screen visual display units

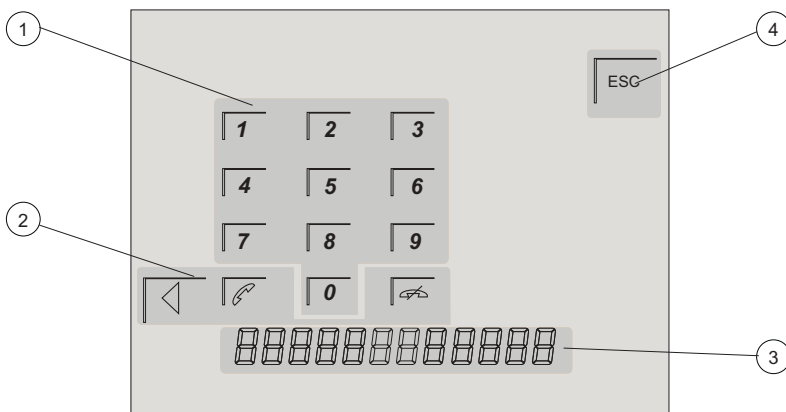

- 1 Numeric keypad buttons.
- 2 Phone command buttons.
- 3 Numeric indicator.
- 4 Screen exit button

Location and appearance of numeric keypad control elements of LCD Touch

The main element of the aS.1001 the user interface is its liquid crystal LCD Touch screen. It serves to enable the user's interactive communication with the device. It is 119 mm wide x 87mm high. In screen units, it is equivalent to 5.7" 4:3 format. It consists of three parts or distinct elements:

- LCD Display
- Backlighting engine.
- Touch Screen Panel.

The LCD display is made to represent and display the controls and meters required for an effective interaction of aS.1001 with the user in attractive way. It has visual elements to represent icons, control buttons and the visual display unit for meters and counters. Each model of the family aS.1001 uses visual elements it needs according to its available features and capabilities.

LCD display type: STN in blue color, negative transmissive. This means that it requires a backlight in order to see the characters correctly and visual elements will make transparent the crystal area and the rest will remain translucent in blue color. This will provide the screen with a special aesthetic appeal

Backlight device is composed of ten LED white diodes, five on each side. This lighting is completely active while the user is interacting with the device. For the purpose of energy saving the system has been provided with a function to turn off the backlight after one minute without the presence of the user in front of the screen.

The resistive Panel Touch-Screen is the element that enables the the user to control the device in order to program it or enter data. It consists of a matrix of 7 x 6 transparent buttons spread across its surface. System is able to detect the specific button pressed checking the row and column activated. The system for detecting the keys pressed is combined with a short audible signal in order to give the user an appealing and lively impression of the touch.

All the controls buttons available in the aS.1001 system can be seen in the figures above. These buttons are activated and look according to the needs of the menu of control.

DIMENSIONS

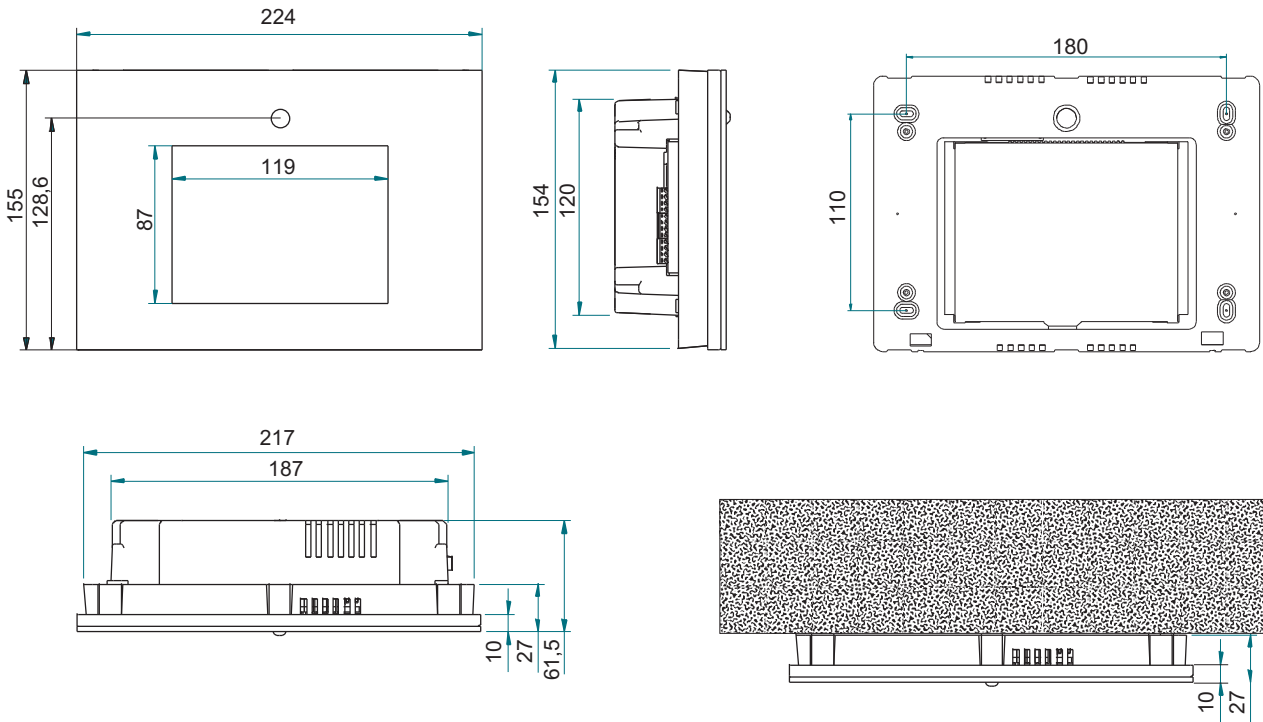

SCREEN VISUALIZATION ANGLES

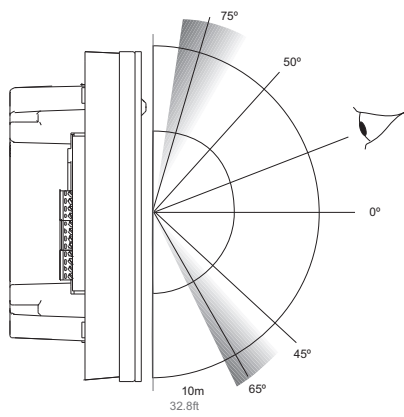

Angles and optimum vertical viewing distances

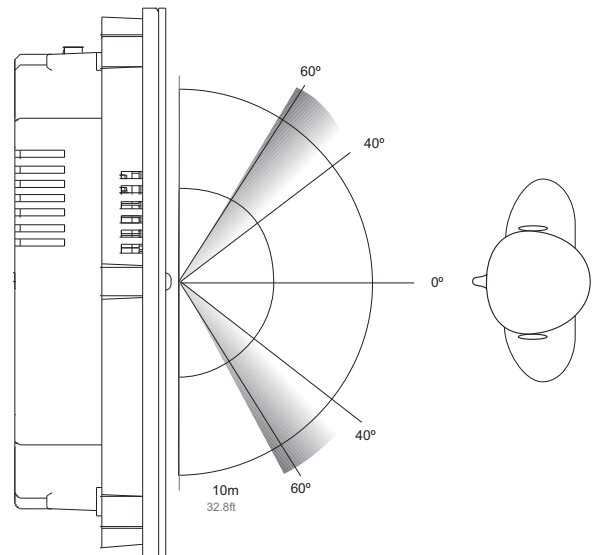

Angles and optimum horizontal viewing distances

The LCD screen of the aS.1001 engine has been designed to be seen from virtually anywhere in the room. Its main meter numbers are designed to be read from more than 10 meters away. Image shows ideal viewing angles.

PRESENCE SENSOR DETECTION

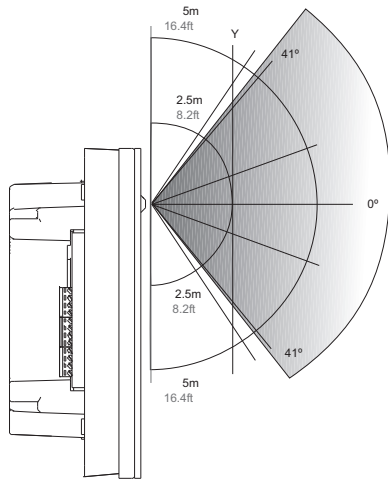

Vertical viewing area

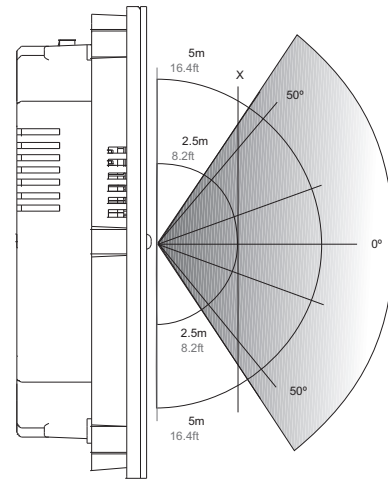

Horizontal viewing area

OPERATION MODE

One of the great advantages of the aS.1001 engine is, without any doubt, its pyrometer sensor of presence. That sensor greatly simplifies the installation and provides the engine with an essential element for a wide range of functions and applications. Sensor works when it detects the motion of a heat source, such as the emitted from a living body.

In view of the small sensor size, the secret of this sensor lies in its lens equipped with 64 detection zones, distributed in vertical and horizontal opening angles of 82° and 110° respectively with a range of 5 meters. These features are more than enough to enable the system to offer for example the provision of a simple and effective intrusion detection. The characteristics of the range of the sensor are represented in the images above.

THERMOVELOCIMETRIC SENSOR

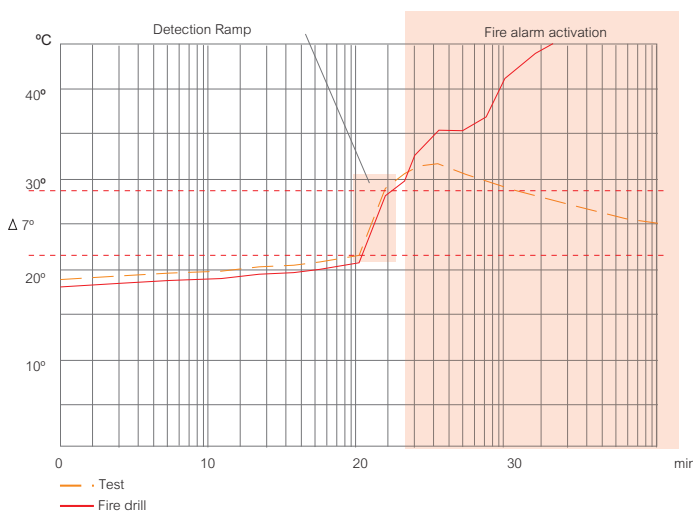

Graph showing the behavior of the thermovelocimetric sensor

OPERATION MODE

aSmart engine is fitted with a temperature sensor type NTC curve K. This sensor essentially enables the engine to determine and measure the room temperature, showing it on the screen and comparing it with the temperature chosen by the user for his comfort. In this way the switch-on of heating/cooling system can be managed. The philosophy of integration that characterizes this range of products enables the system to infer a possible fire in the proximity of the device, with this same sensor and just adding a smart algorithm to the system software. You can see in the graph the way the temperature sensor emulates the operation mode of a fire thermovelocimetric sensor. This type of sensors determines the existence of a fire on the basis of a sudden increase of temperature at a rate of 7°C/minute.

In the graph both the test-curve and the fire drill indicate that the ramp of detection corresponds to a temperature rise that the device will be interpreted as a fire, triggering a succession of warnings to alert the user.

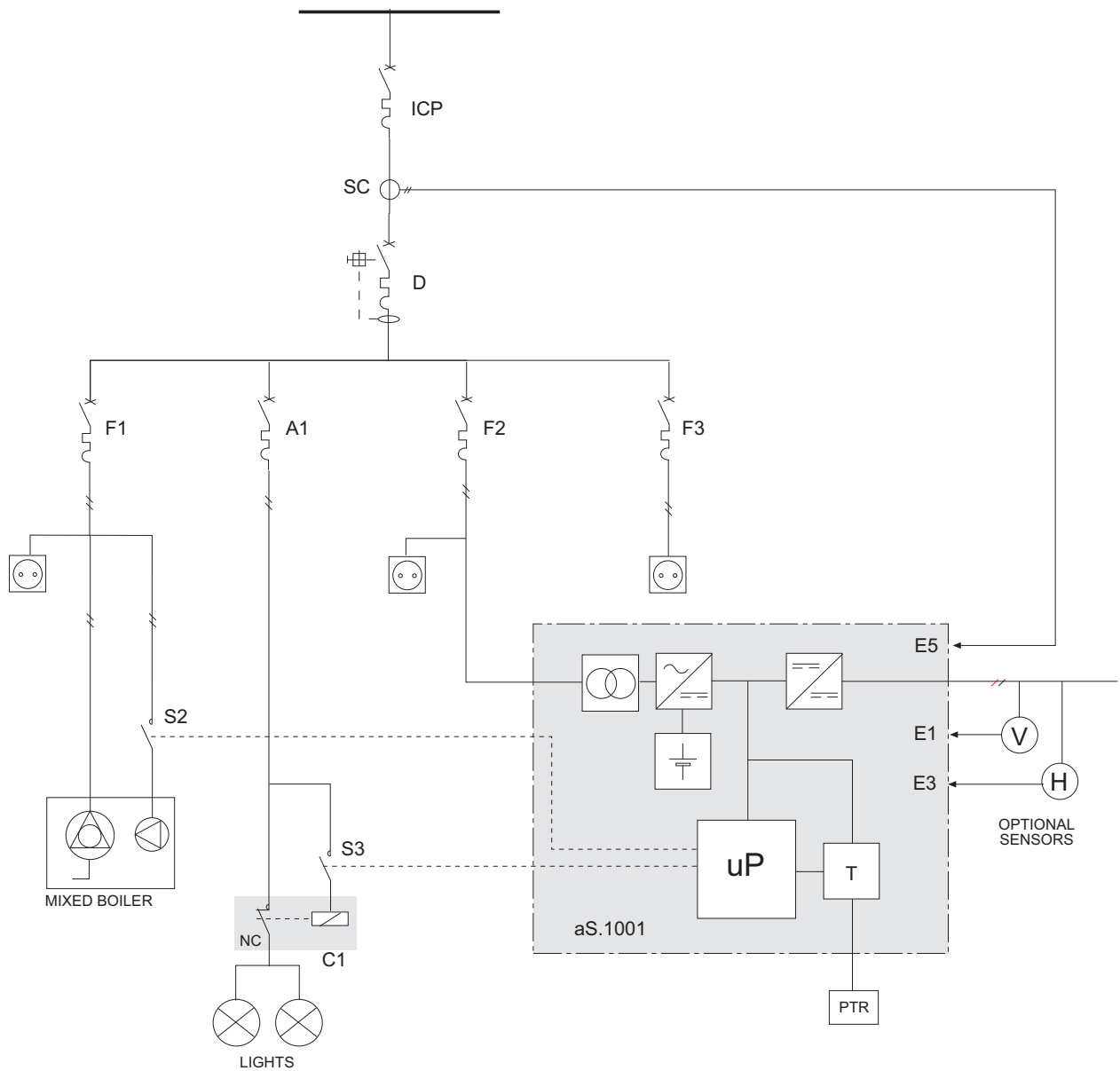

SINGLE-LINE ELECTRICAL DIAGRAM

In this Diagram there is a detailed view of the system electrical installation. aS.1001 manages directly with S2 the thermostat circuit that will put into operation the radiator water pump in a mixed boiler. This circuit will be protected by the thermal-magnetic circuit breaker rating F1 where the boiler is connected. For the implementation of the lights energy-saving, it will be necessary to cut the lighting circuit, protected by A1, through a usually closed contactor C1. As it is shown this contactor coil manages aS.1001 with S3. This way in stand-by mode the supply of the lighting is guaranteed. Only when aS.1001 order the contactor to cut, then the power supply will be interrupted in order to save energy.

The current SC meter device will be located between the ICP circuit breaker and the differential, by inserting it into the phase wire. The signal wires will be connected between the aS.1001 GND terminal and its own, E5.

It could be optionally connected two additional circuits of security sensors. As it is shown, in the diagram inputs E1 and E3 are each of them capable of lodging security circuits of intrusion and technical security of fire respectively.

CONNECTION DIAGRAMS

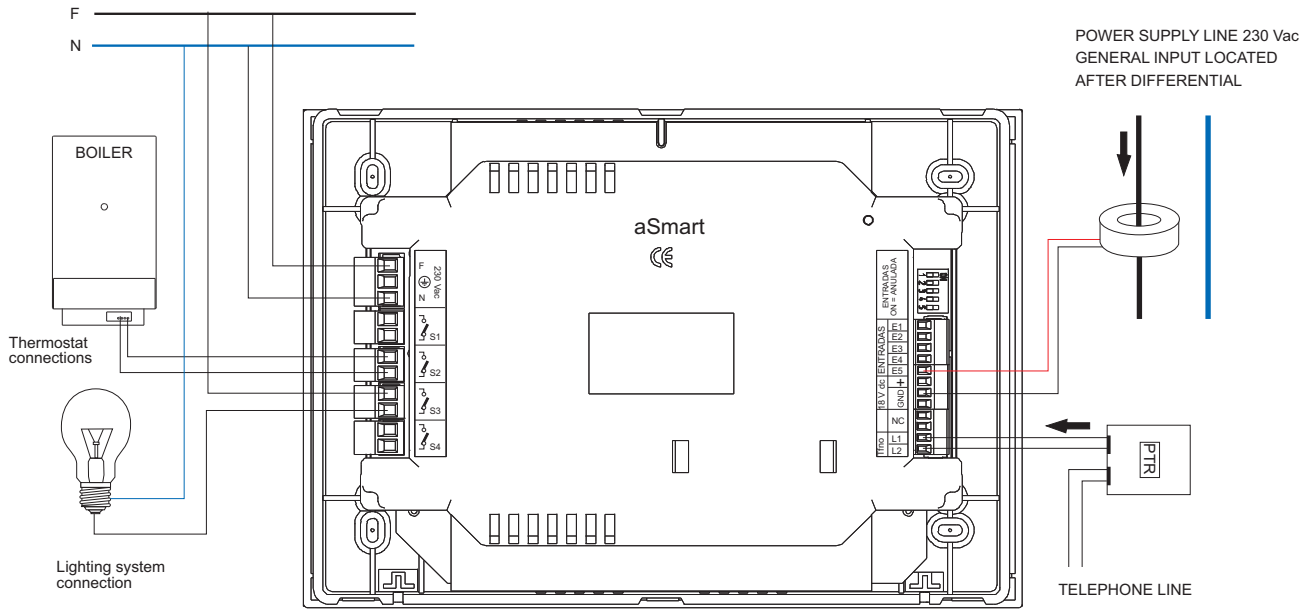

Basic installation schema

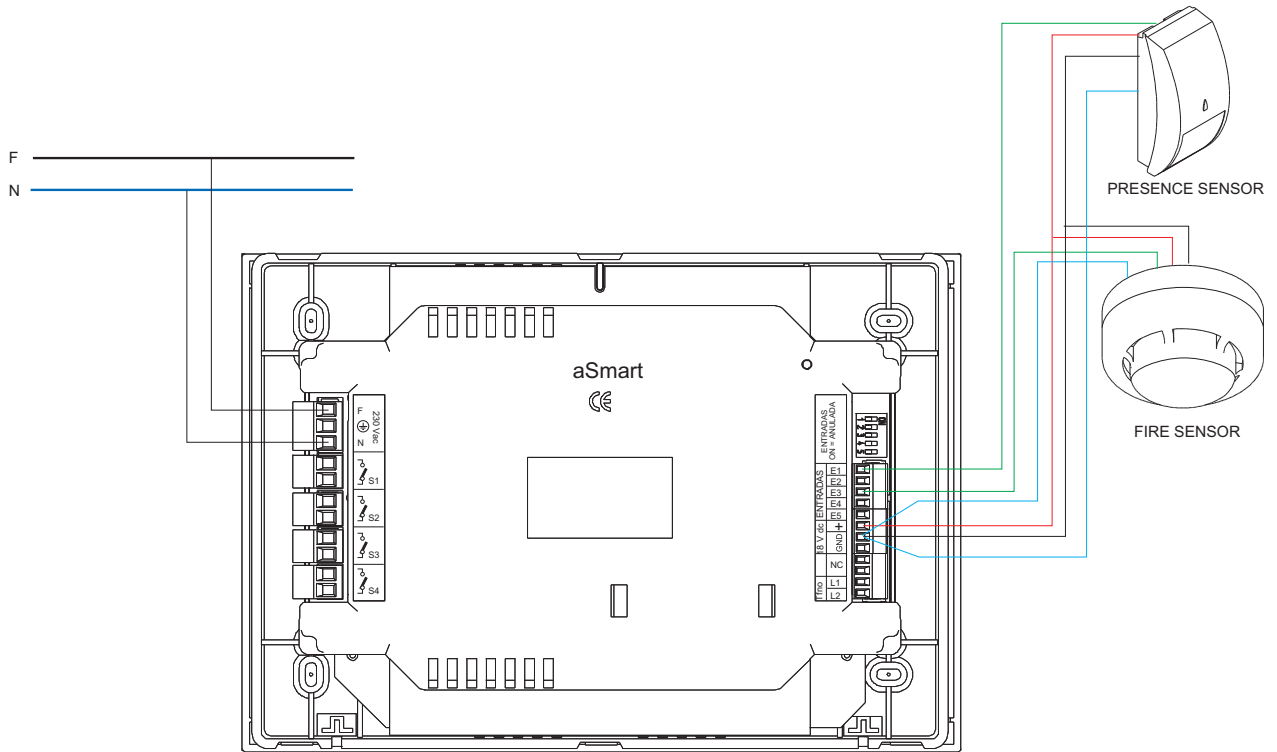

Installation diagram with optional external sensors

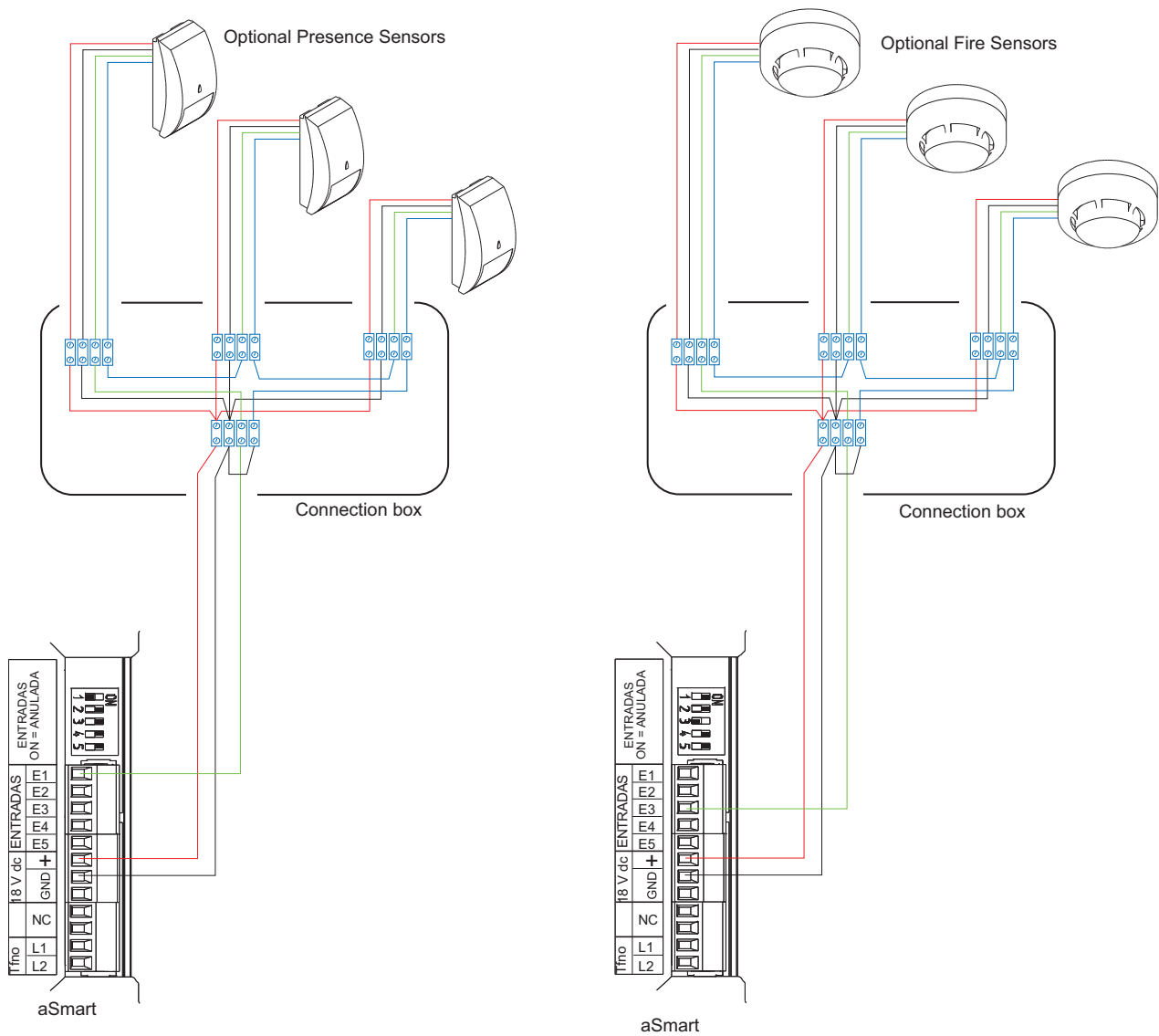

Installation diagram with optional external sensors

CONNECTIONS IDEAS

In the image are shown some installation ideas when there are more than one sensor (motion or fire) to be wired up. Power supply should be driven from aSmart to each of the sensors. aSmart is able to manage several sensor from single input. On this purpose it will be necessary the serialization of the usually closed potential-free contacts outlets, available in sensors, so that one of the ending terminals will be connected to the GND negative and the other ending terminal will be connected to the aSmart E corresponding enabled input. Input E1 will be used for the external presence sensors and Input E3 for the external fire sensors. In all cases, it will be necessary to check that the corresponding micro-switches are in OFF mode unpitting the input, enabling the set of optional sensors installed to operate.

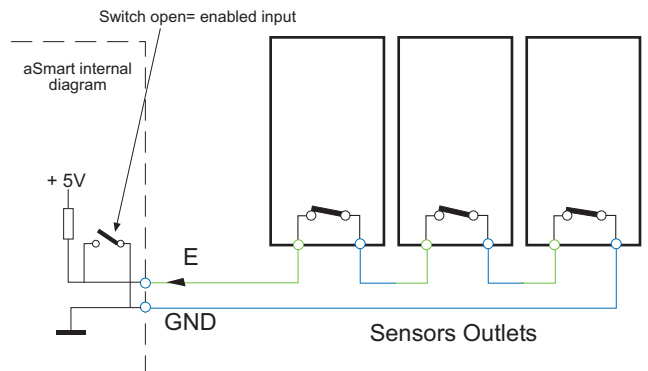

Concept Schema

TECHNICAL DATA

Features	Terminals	Description
----------	-----------	-------------

POWER SUPPLY INPUT

Voltage of power supply	F (Phase)	230 Vac 50Hz (127 Vac 60Hz available upon request)
	N (Neutral)	
	(Ground)	

EXTERNAL SENSOR INPUTS

Inputs	E1 (Input 1)	* Intrusion Sensors in closed loop with GND
	E2 (Input 2)	Not implemented. Switch to On
	E3 (Input 3)	* Fire Sensors in closed loop with GND
	E4 (Input 4)	Not implemented. Switch to On
	E5 (Input 5)	Current Sensor

VOLTAGE OF THE POWER SUPPLY OUTLET TO EXTERNAL SENSORS

Power source outlet	(+) Positive	15 Vcc Positive with charge (Max. 150 mA)
	GND	In case of power outage the internal battery will keep supplying this 15 V

OUTLETS

NA Potential-free contacts relays	S1 (Outlet 1)	Not used
	S2 (Outlet 2)	Heating/cooling control. Maximun 16A to 230 Vac
	S3 (Outlet 3)	Lighting control. Maximun 16A to 230 Vac
	S4 (Outlet 4)	Not used

LOCAL THE USER INTERFACE

Screen	5,7"transflective LCD Custom Screen blue	
	10 white led's backlight	
	Resistive Touch panel	
Microphone	Unidirectional condenser microphone	
	Sensitivity -40dB, S/N 50 dB	
Loudspeaker	Impedance ratings of 8 Ohms	
	Maximum power 2W	
	Frequency Pass-Band 400 Hz to 20 Khz	
	Local Pre-recorder voicemail messages	
Beeper	Dissuasive Siren	
	An acoustic signal sounds every time screen is pressed	
Messages Recorder	Up to a maximum of 9 voicemail messages (30 seconds message time)	

*These outlets are optional. In case you do not need to use it, please be sure to verify that corresponding switches are in ON mode.

TECHNICAL DATA

Features	Terminals	Description
REMOTE THE USER INTERFACE		
Telephone Line input	L1	Outlet: Guided Menu of pre-recorded voice
	L2	Input: DTMF Multi-Frequency Tones
		ADSL filter included
Answering Machine	Factory default pre-recorded voicemail outgoing message The user's own outgoing greeting message	
Avisador de alarmas	Factory default pre-recorded voice alerts	
PROTECCIONES		
Outlets	Varistors, 260V, between contacts	
Inputs	Polarity reversal	
Phone Line	Fast transient protection and induced surges using gas discharge tubes.	
SENSORS INCLUDED		
Pyrometric of Presence	Maximum range: 5 meters Horizontal angle: >100° Vertical angle: >82° Detection Zones: 64 Movement speed: 1m/s	
Temperature	NTC curve K Temperature range of 0 to 40°C	
Fire Thermovelocimetric	Using algorithm of software	
Presence 230V of power supply	Continuous internal sensor	
EXTERNAL CURRENT SENSOR		
Internal Diameter	11 mm maximum	
Nominal Intensity Measurement	From 2 to 90 A, Cos ϕ = from 0,8 to 1	
DIMENSIONS		
Width- height – depth (mm)	224mm x 155 mm x 61,5 mm	
Installed	224mm x 155 mm x 27mm	
OPERATION TEMPERATURE LEVEL		
Home Temperature	From -7°C to 50°C	

avanza

Pamplona - SPAIN

Tel. +34 948 25 84 24

www.avanzaengineering.com

info@avanzaengineering.com